



NICOMATIC is certified
ISO9001:2008 / EN9100:2003

16068-MO MANUAL PRESS 1.27mm pitch



NICOMATIC is now enriching the **CRIMPFLEX®** connector range to provide even **more space and cost-savings solutions** thanks to the **1,27 mm pitch**. Our specifically designed **Crimping Press** allows you to crimp up to 50 contacts in a single operation in order **to increase your productivity and eliminate any risk of pitch drift** during the crimping process.

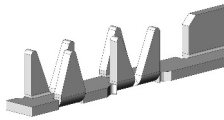

The contact crimping is achieved by piercing the conductor in 6 points, in order to ensure both outstanding **mechanical retention** by 2 points and **electrical continuity** by 4 points.
CRIMPFLEX® system patented by NICOMATIC

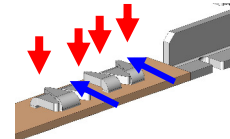

FEMALE CONTACT P/N 16068

MALE SOLDER TAB P/N 16069

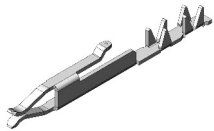

16068-12 tin plated
16068-32 selective gold



16069-12 tin plated

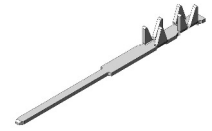

- for 0,38mm (.0015") to 0,45mm (.0018") pin header
- Ni 2μ + Sn 5μ and optional selective Au plating 0,15μ on mating area

- recommended for flexible supports requiring male solder tabs
- Ni 2μ + Sn 5μ

PACKAGED IN REEL
BY 33 000

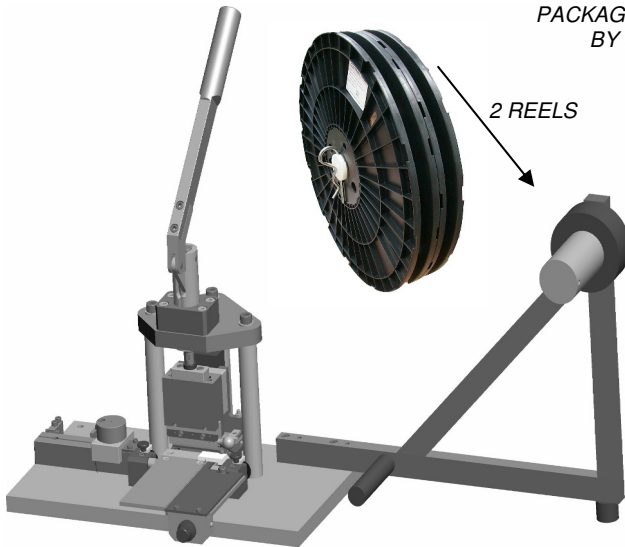

ADVANTAGES

- First press to crimp from 2 reels at a time in a 1.27mm pitch and **high productivity rate** (up to 6 cycles per minute)!
- Crimps from 2 to **50 contacts in one stroke!**
- Answers **market miniaturization trends** (higher contacts density)
- Compatible connection with **1,27mm headers**
- Contact mechanical retention **outperforms ZIF** type connectors

FEATURES

GENERAL DATA

The contacts are moved forward from stop to stop by hand via the side loader. The graduated positions correspond to the number of contacts to crimp (2 to 50 points)

The crimping is operated manually via the upper lever. Two reels are fixed onto the reel support.

TOOLING

This machine is available in 1 version and provides the possibility to crimp male solder tabs, or female contacts.

ORDERING INFORMATION

16068-MO

For contacts: 16068 and 16069

FPC (Flex Printed Circuit)

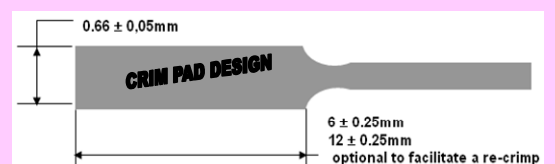

16068-MO MANUAL PRESS

1.27mm pitch



How to crimp in only 5 steps?

MAY 2011 - non contractual document - NICOMATIC reserves the right to discontinue the production or to change the specifications of any part of this data sheet without prior notice - ©

1. Install 2 reels on the support, and select the number of contacts to be crimped

1

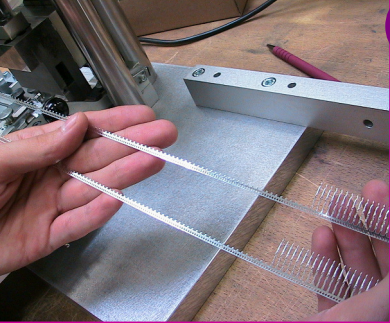
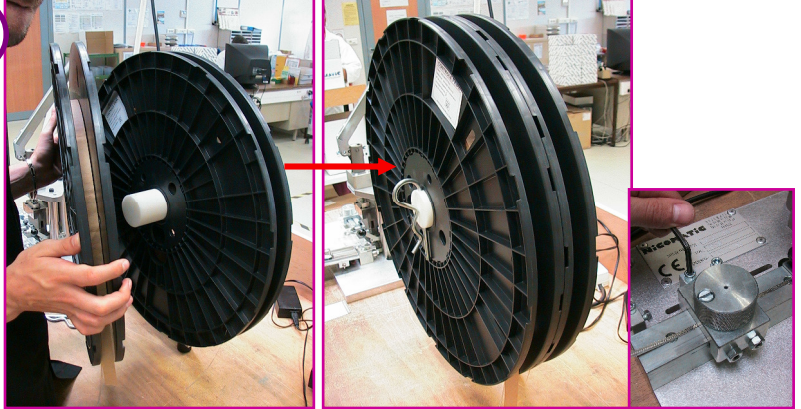

2

2. Unroll the cable and retrieve the paper protection

3

3. Position the 2 strips of contacts on top of each other (1st reel in front of you on top of the rear one)

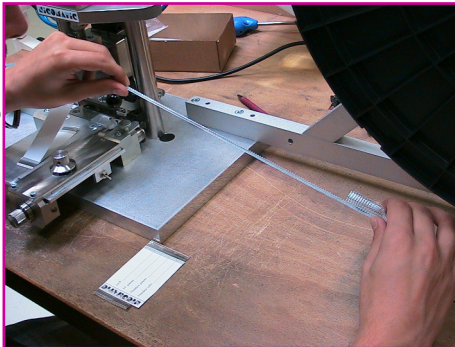
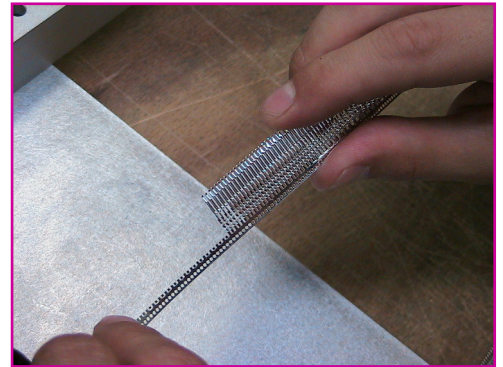

4

4. Place the 2 parallel strips onto the pins and stop the reel of contacts with the 1st bolt action on the right side. Then crimp as indicated on 5th step until the stop

5

5. Test crimping with the positioning system

- Place the cable to the right side until stop
- Use the needle and LED light
- Lock the contacts by using the lever
- Crimp

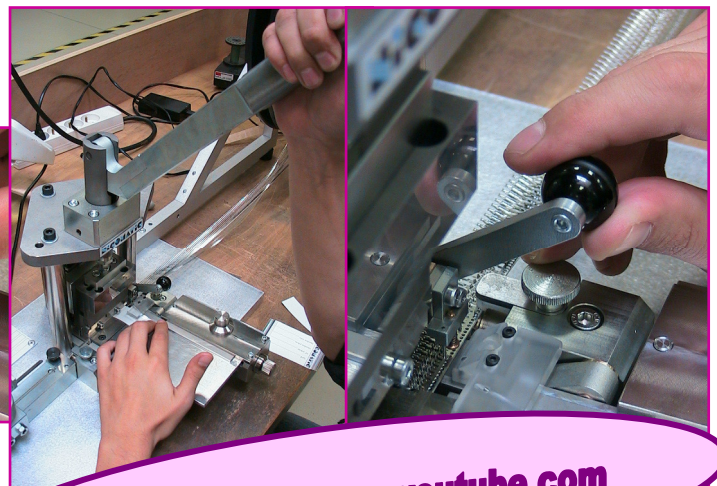

Available on www.youtube.com